

Confined masonry

An illustrated guide for masons

This manual explains this technique

RC frames

Columns first, walls after

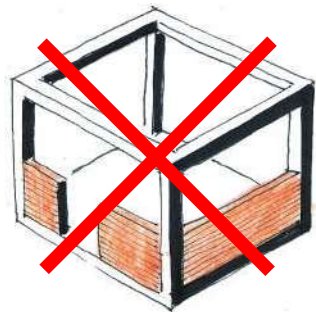

Confined masonry

Walls first, columns after

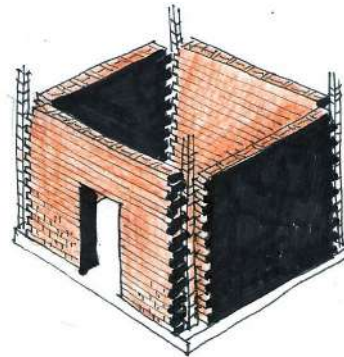

1. Site selection and form of house

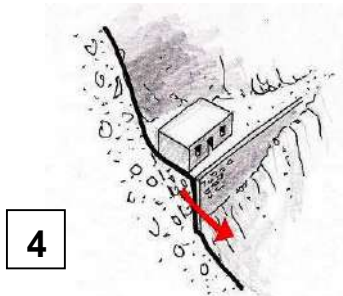
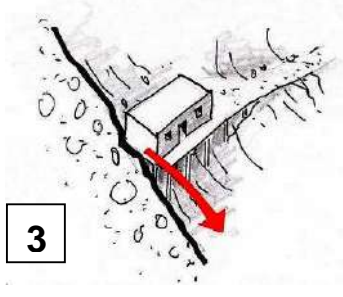
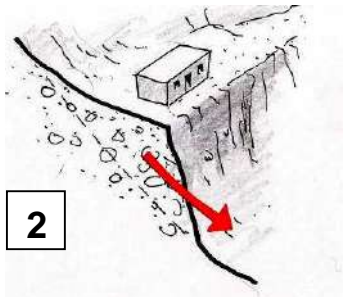
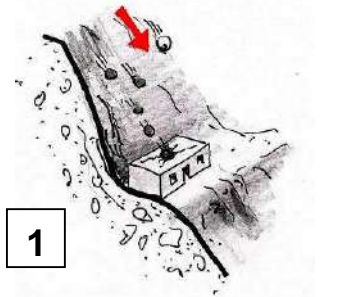

1. Don't build too near to a steep slope: stones might fall on your house.

2. Don't build too near to a precipice: it might break off during an earthquake.

3. Don't build on stilts: they will fall over during an earthquake.

4. Don't build too near to a retaining wall: it might break away during an earthquake.

5. The house must have a simple form. If necessary, subdivide it into rectangular parts.

6. The house must not be longer than 3 times its width.

7. A light, pitched roof is better than a heavy concrete slab.

8. Don't build higher than 2 floors.

9. Don't build on columns.

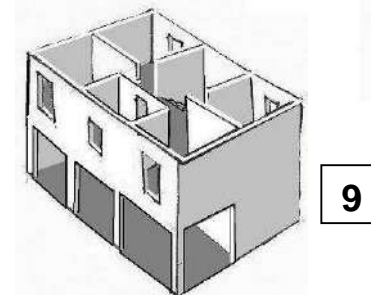
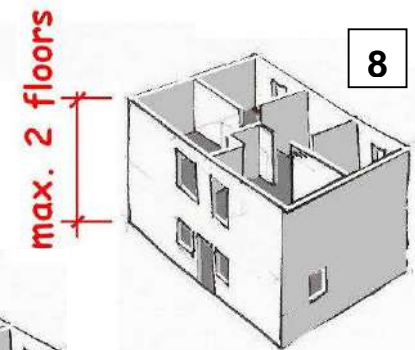
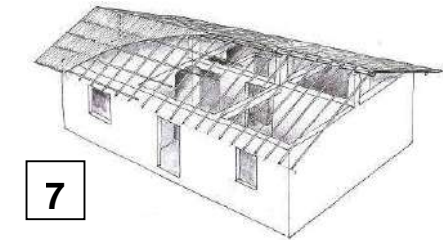
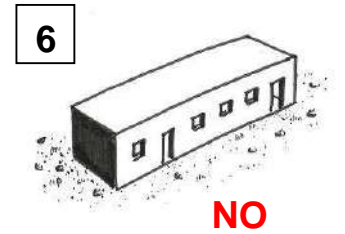
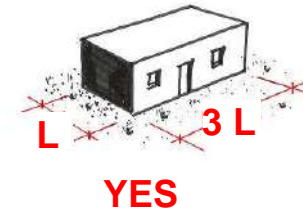
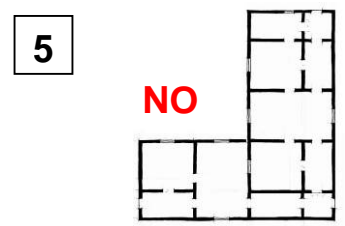
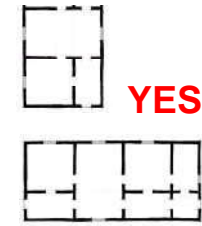

2. Basic rules

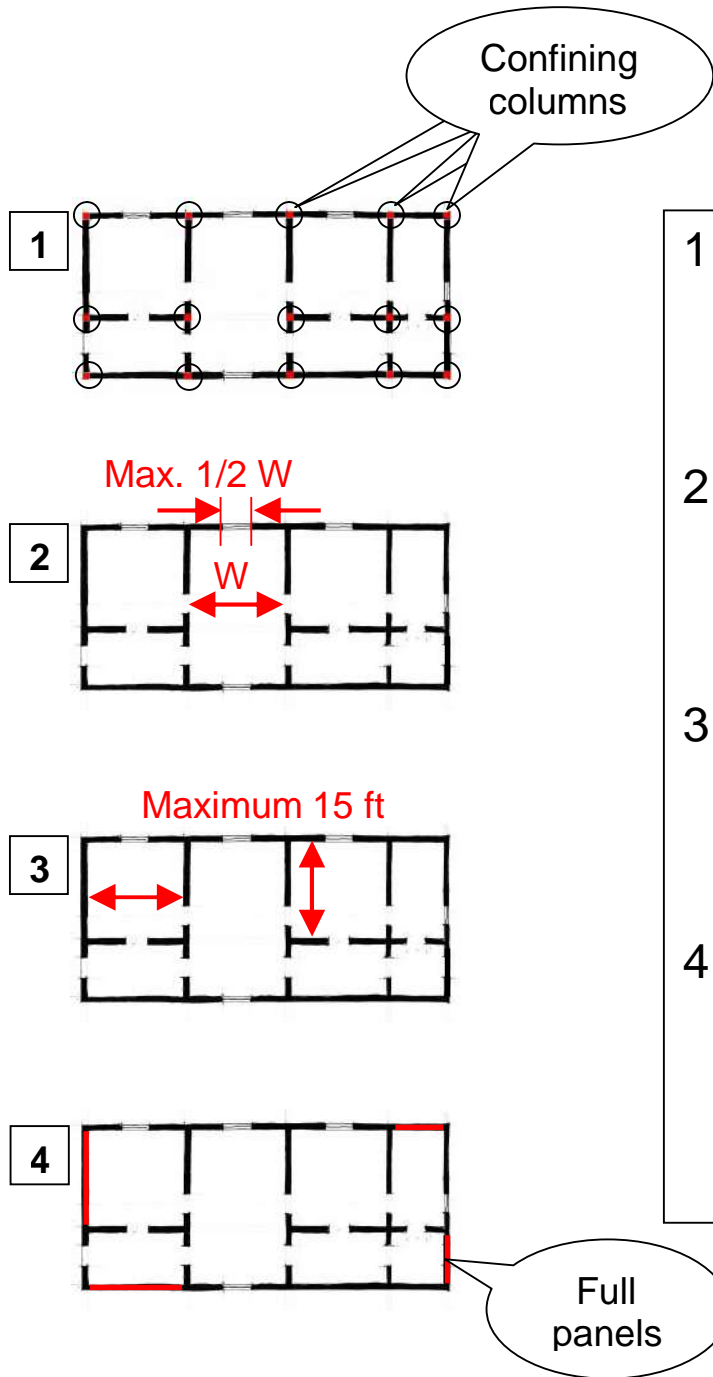

1. Place the confining columns at every intersection of main walls.
2. Width of window must be smaller than half the distance between columns.
3. Walls must be connected with a perpendicular wall at least every 15 feet.
4. Keep as many wall panels without windows as possible, but at least one on each outer wall.

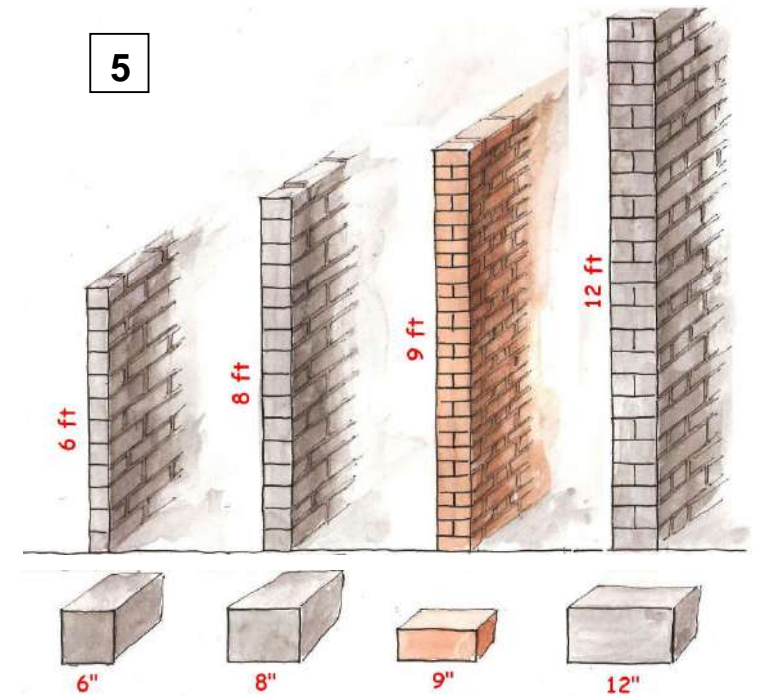

5. Walls must not be higher than 12 times their thickness: for every inch of thickness one foot of height.
6. Always build with good, solid bricks or blocks. Never use hollow blocks with this building method!*



* Limitation on hollow blocks not included in Urdu version of this handout!

3. Column reinforcements

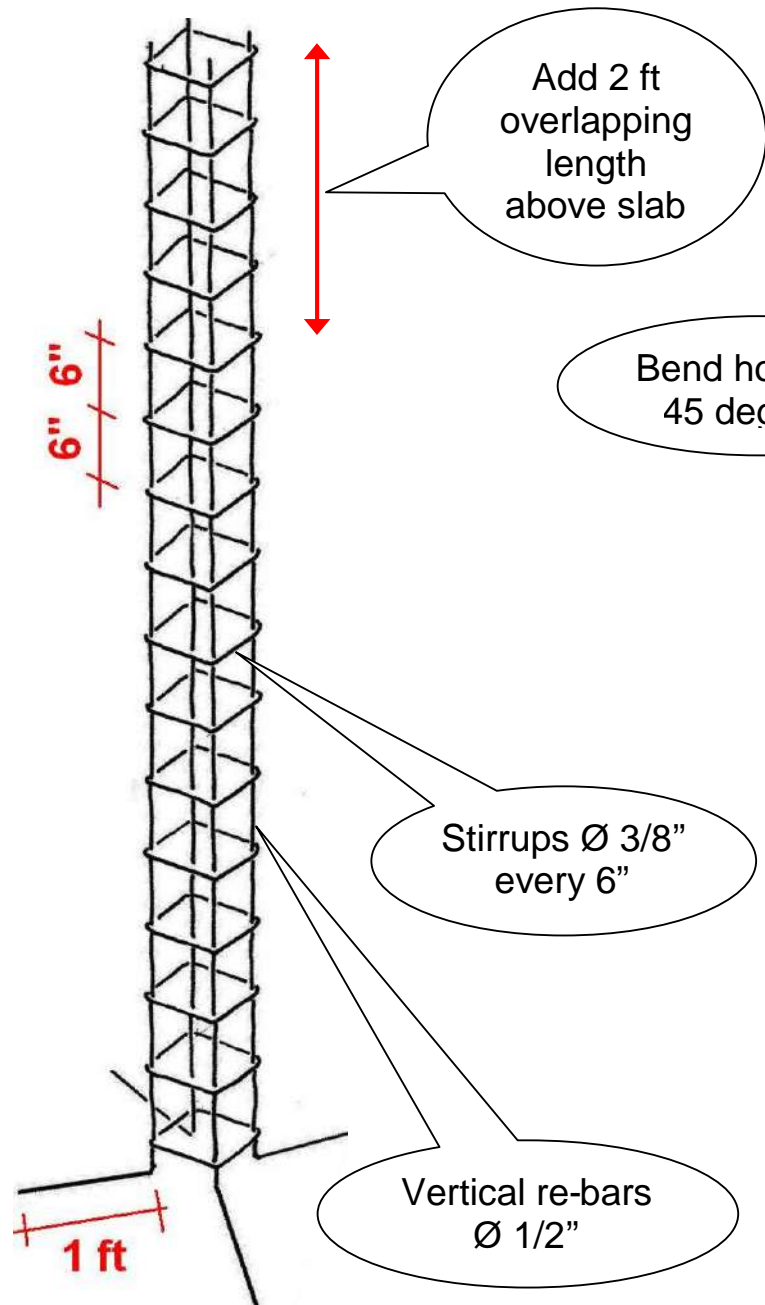

1. Calculate length of the vertical re-bars from the bottom of the foundation until 2 1/2 feet above the slab.
2. Start with 1 ft long feet at the bottom.
3. Place stirrups every 6 inches.
4. Bend stirrup ends at 45 degree angles and alternate their position.

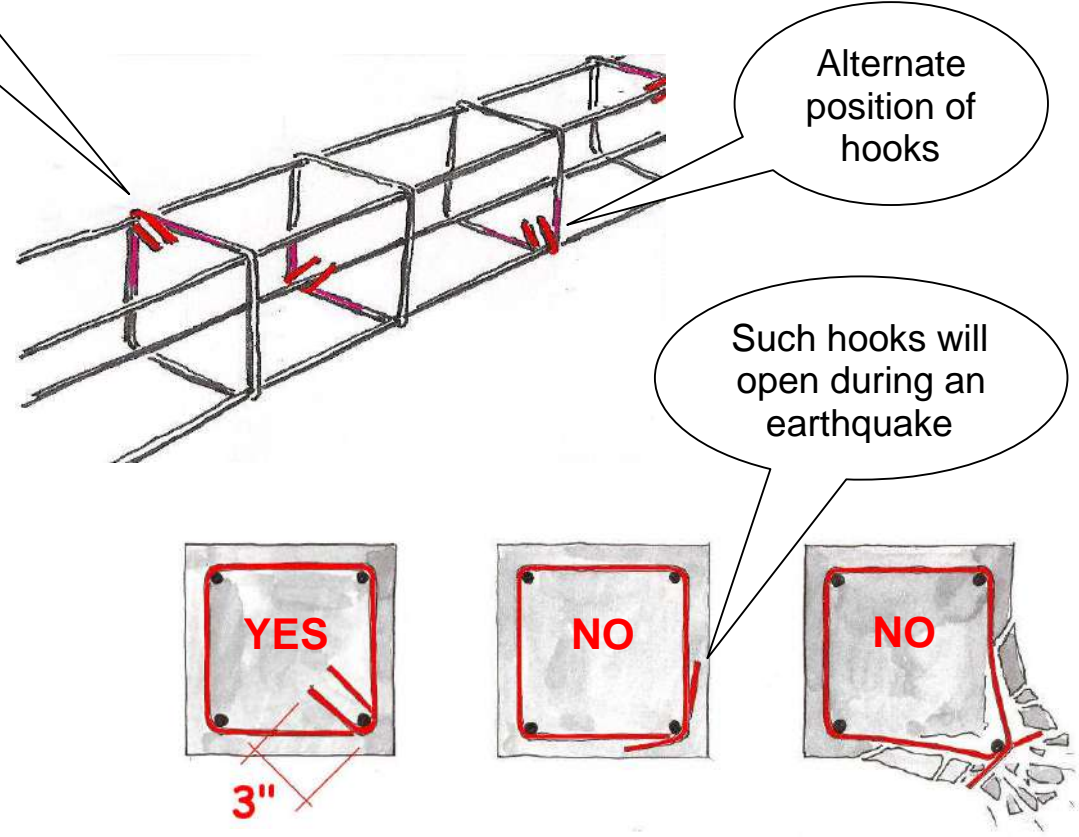

4. Foundations

1. Dig the trenches 2-3 feet deep and 2-2½ feet wide (larger on soft soil, narrower on hard soil).
2. Place the columns reinforcements on a 2 inch bed of lean concrete.
3. Make the foundation with stones and concrete.
4. Ensure that the column reinforcement is filled with concrete, not with stones.
5. Let the foundations come 1/2 foot out of the ground.
6. (If you prefer foundations in reinforced concrete, follow the instructions on the ERRA poster).

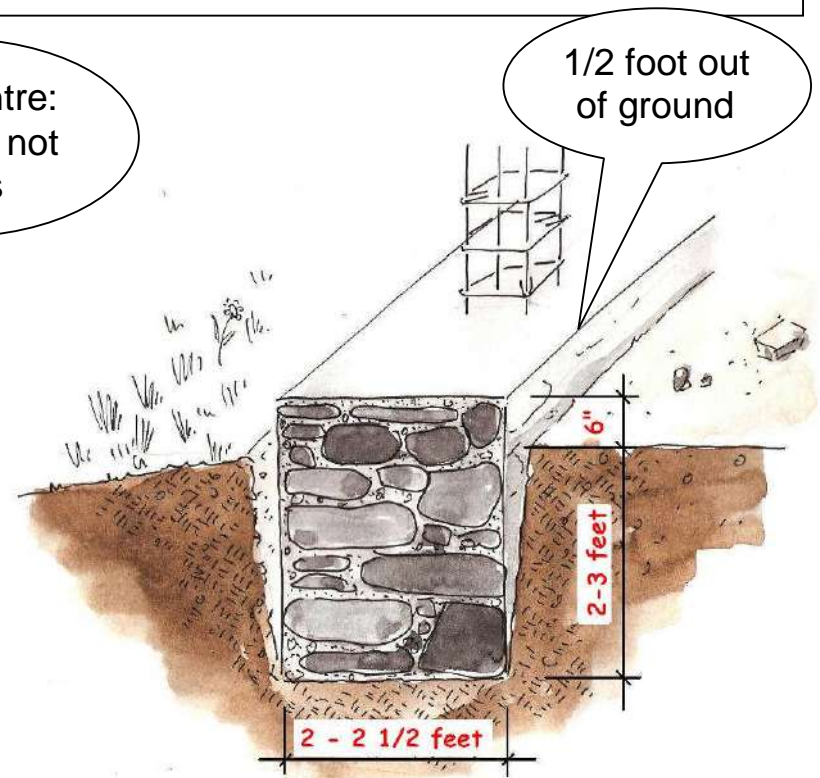
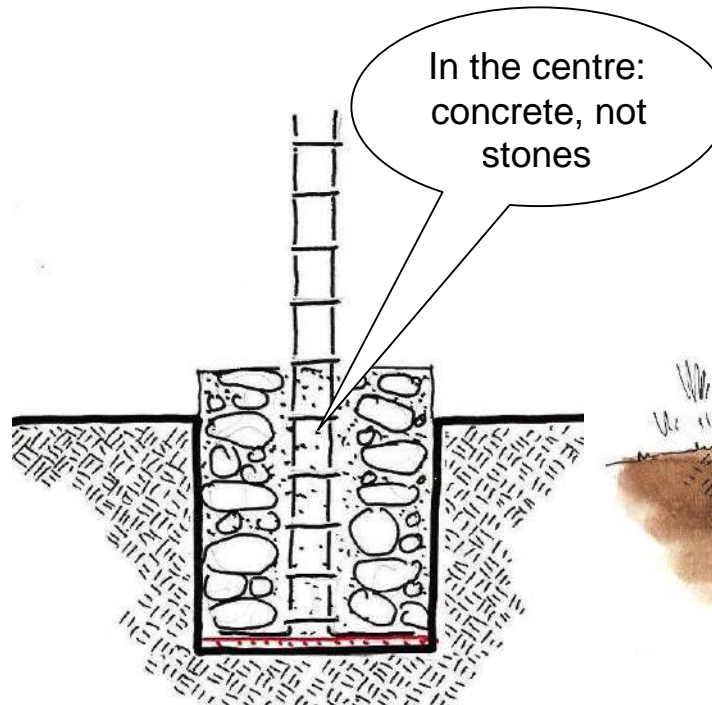
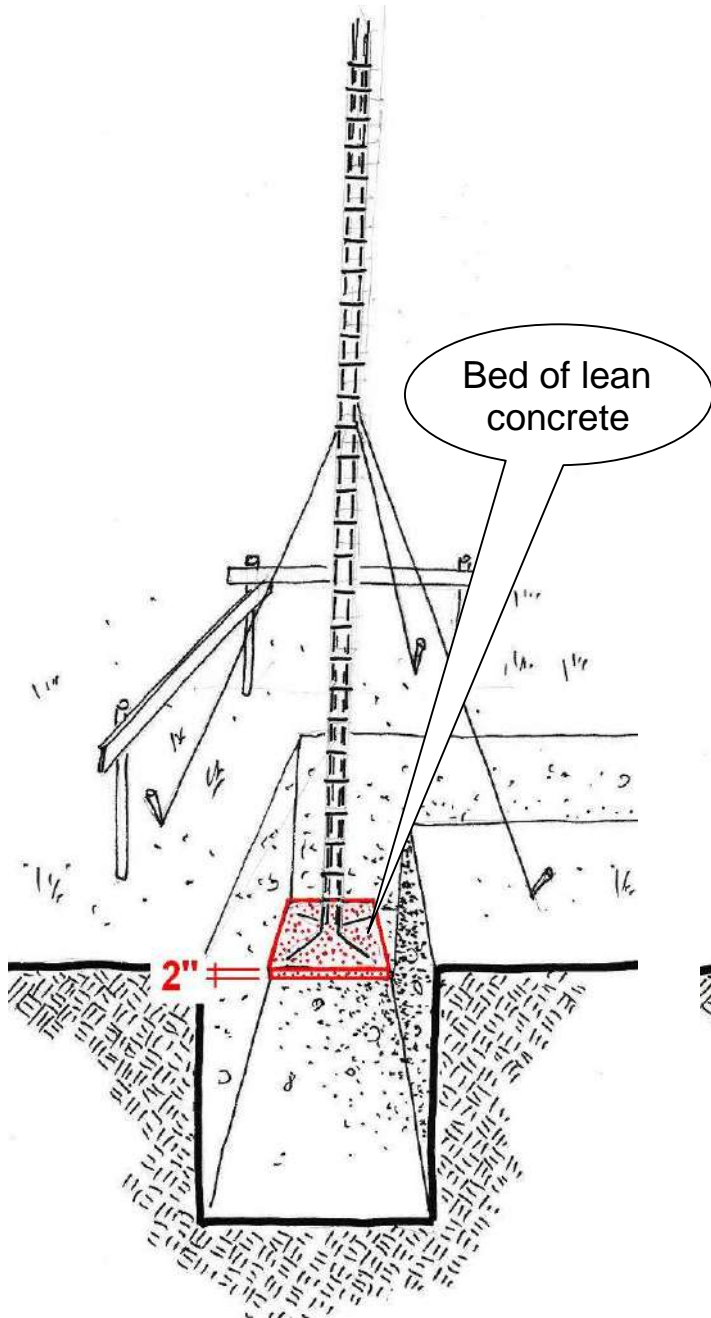

5. Plinth beam

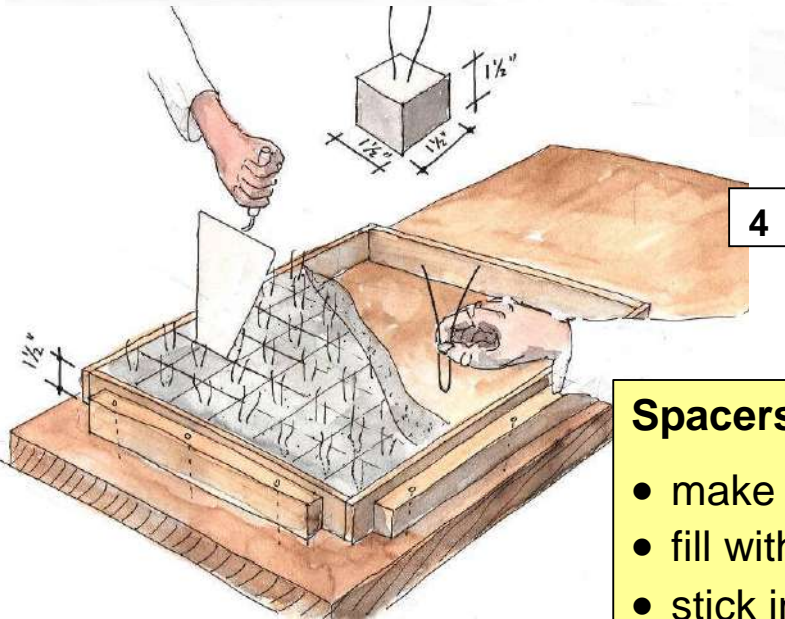
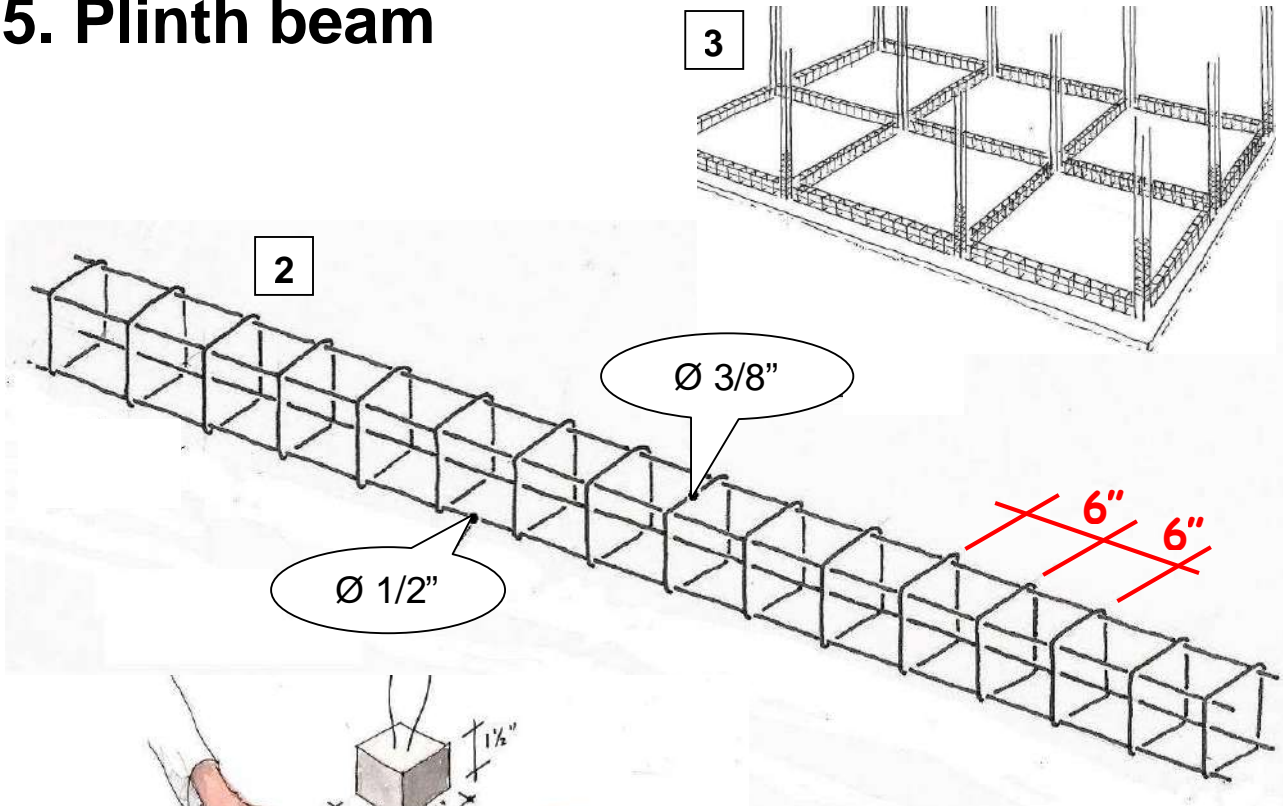

Spacers

- make a mold 1 1/2 " high.
- fill with mortar
- stick in the wire loops
- cut the mortar with a trowel, into pieces of 1 1/2 "x 1 1/2 "

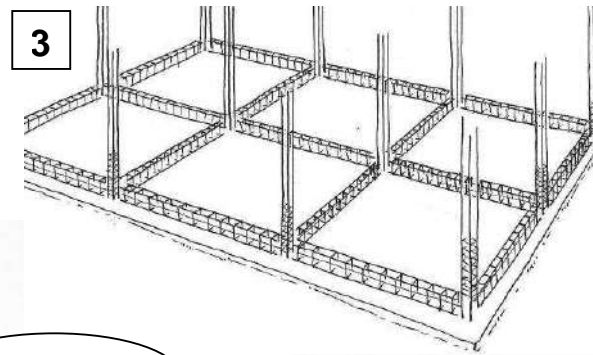

1. Plinth over a stone foundation must be 9" high. Width must be like the wall above.
2. Prepare the plinth reinforcements with stirrups at a distance of 6 inches.
3. Place the plinth reinforcements between the columns on the foundation.
4. Prepare spacers 1 1/2" thick.
5. Put the spacers under the plinth reinforcements every 2 feet.

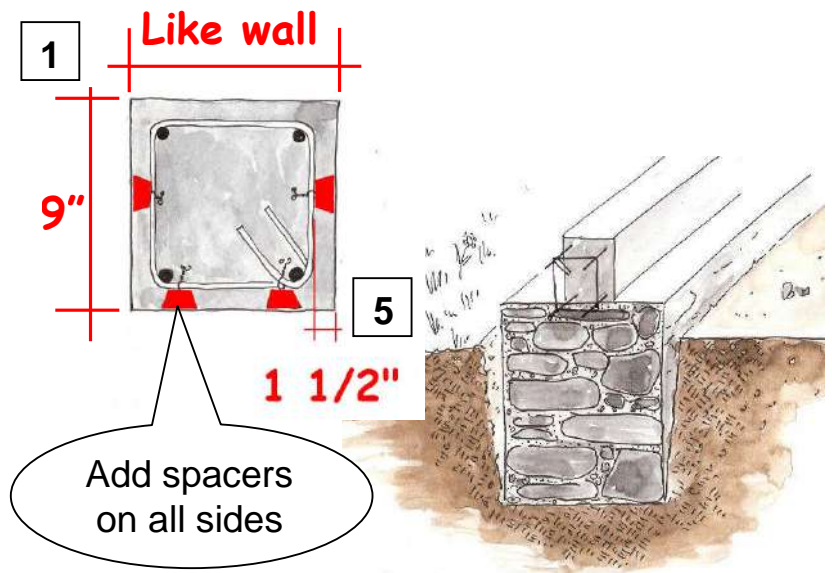

Add spacers on all sides

6. Plinth beam connections

1. Connect plinth beams through the confining columns with 4 straight bars.
2. These bars must enter 2 ft into the plinth, on both sides of the column.

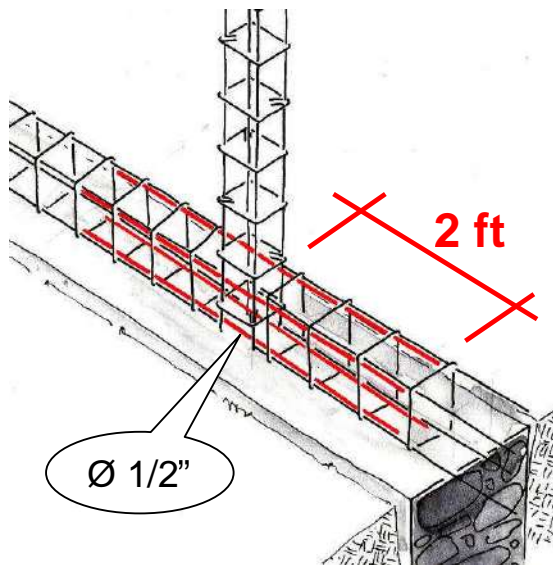

Method 1: L shaped re-bars

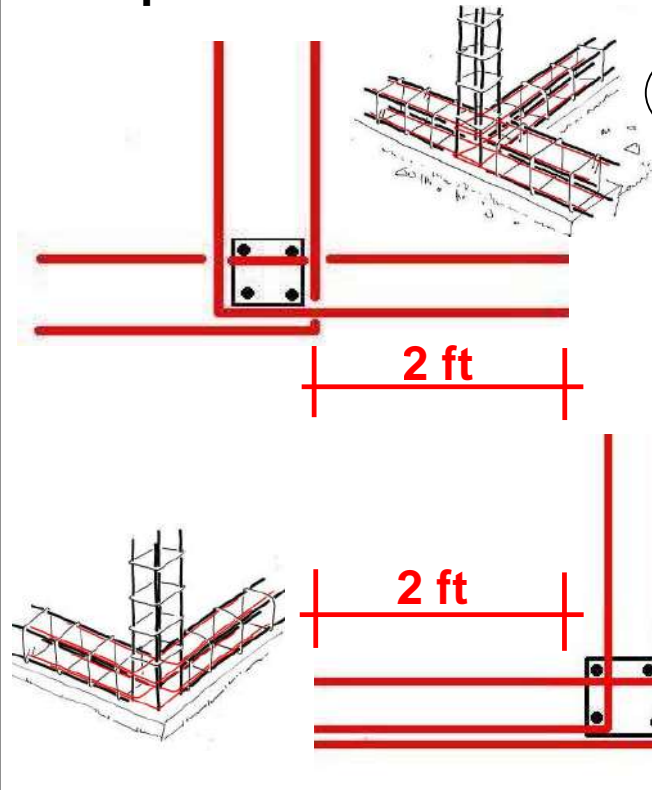

Method 2: U shaped anchors

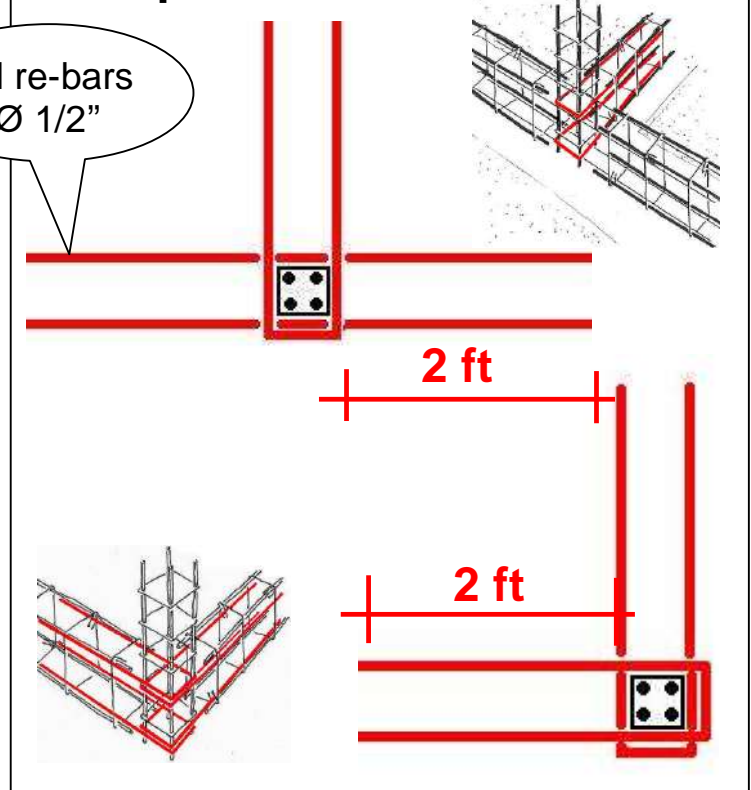

3. You can use **L shaped re-bars** or **U shaped anchors** to connect perpendicular plinths.
4. The re-bars and anchors must enter the plinths for a length of 2 ft.
5. Make sure the re-bars and anchors go **inside** the stirrups!

7. Masonry

1. Water the bricks before use. Soaking them in a trench is even better.
2. Avoid continuous vertical joints.
3. If there is no confining column, connect minor walls by alternating the courses.
4. Don't build higher than 4 feet per day.
5. Protect the wall with a plastic sheet in hot weather so the mortar will not dry out.

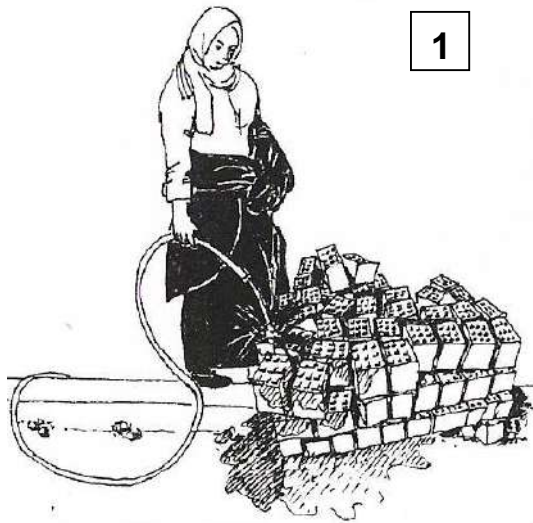
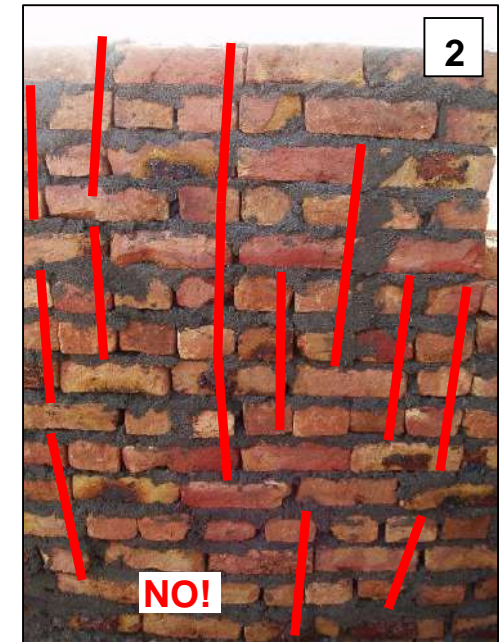

Mortar

- Cement: 1 part
 - Sand: 4 parts
- Mix while dry, only then add the water

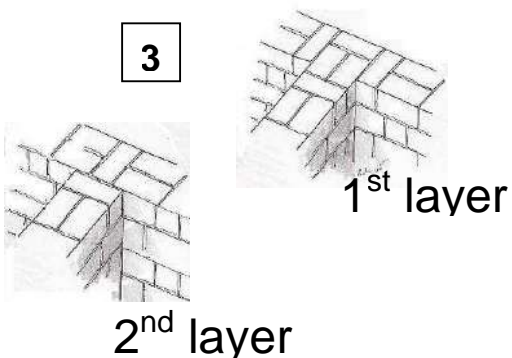
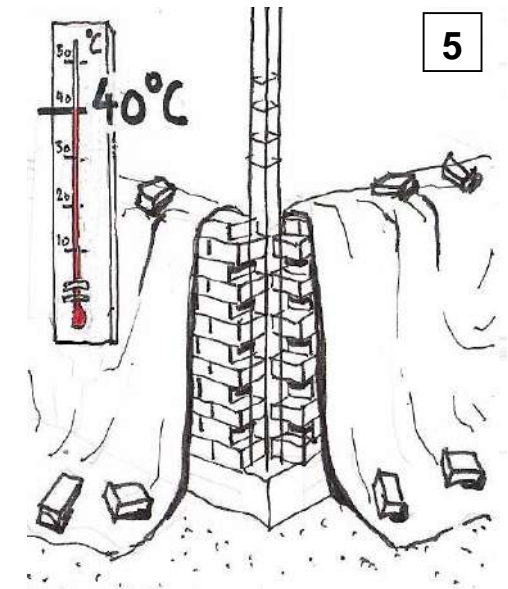
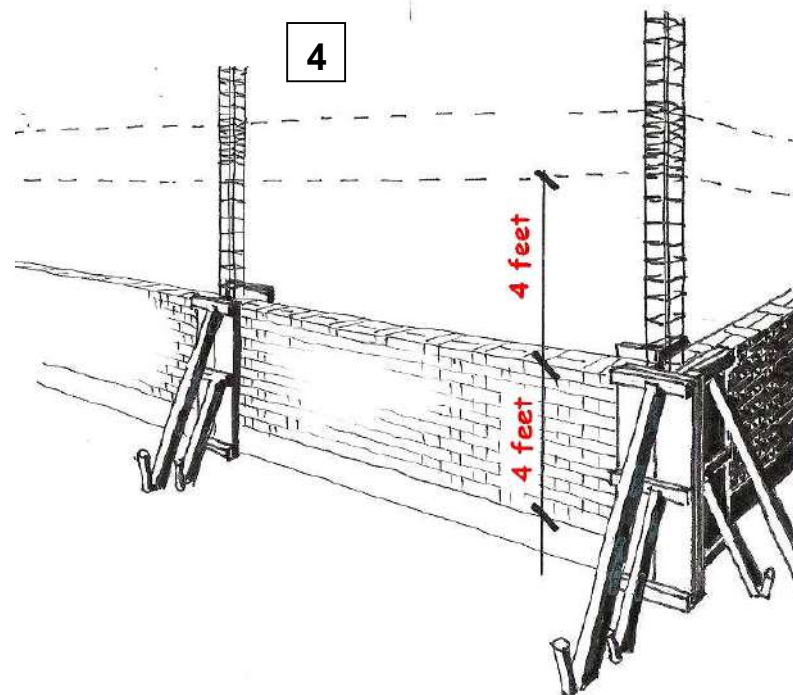

8. Confining columns

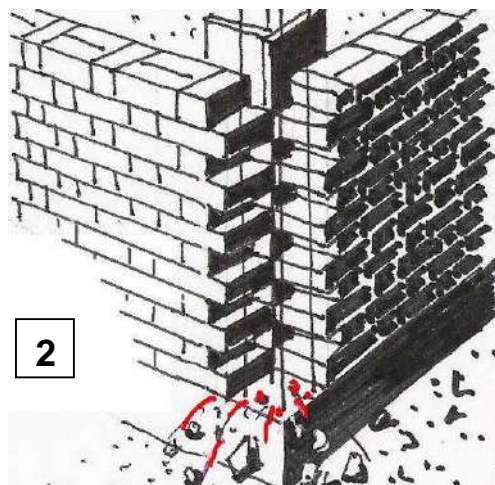
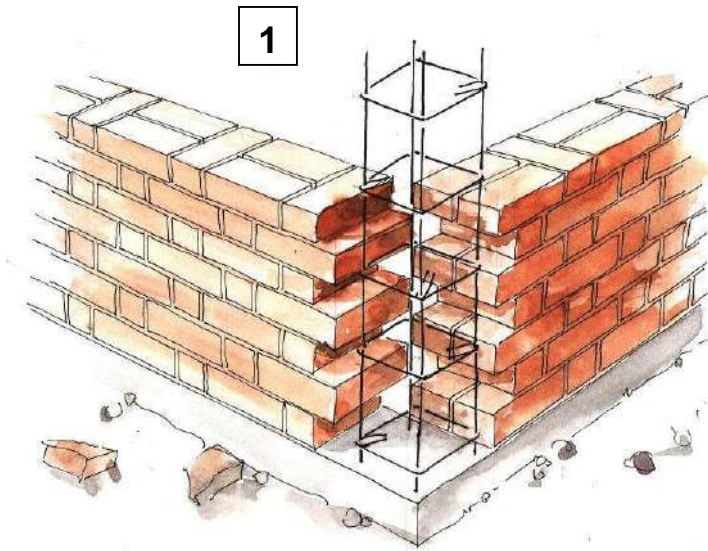

1. Wall ends towards confining columns must be toothed.
2. Clean the column space of all rubbish before adding the form work.
3. Prepare the seismic bands (see next page).
4. Pour the concrete for the bands and the columns at the same time.
5. Compact the concrete with a stick if no vibrator is available.
6. Take off the form work only after 3 days.
7. Water the concrete twice a day for 3 more days. Cover with a plastic sheet in summer.

Concrete

- Cement: 1 part
- Coarse sand 2 parts
- Crushed gravel 3/4": 4 parts
- Water: 1 part

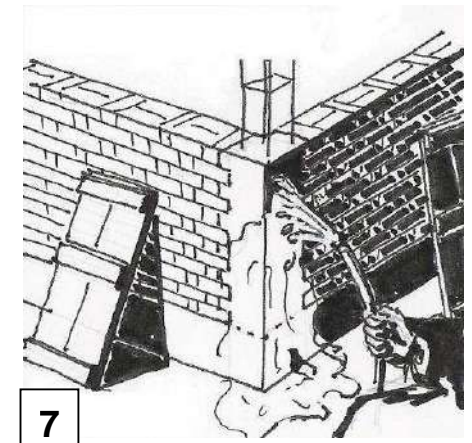
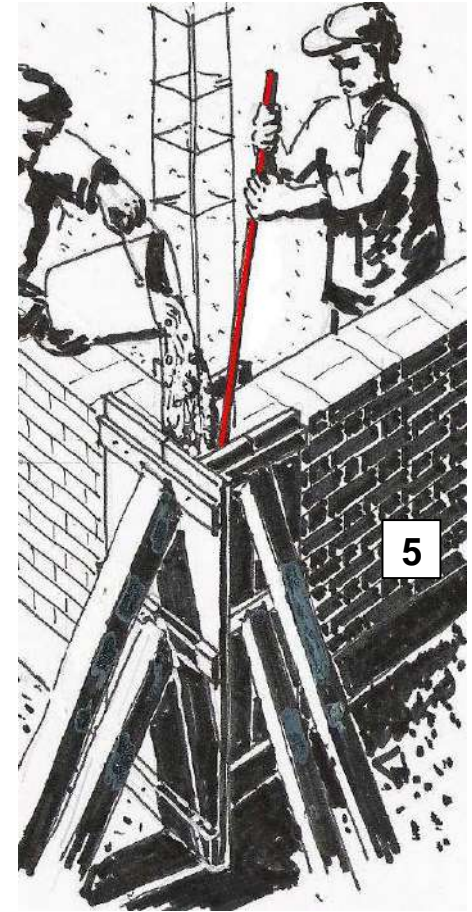

9. Seismic bands

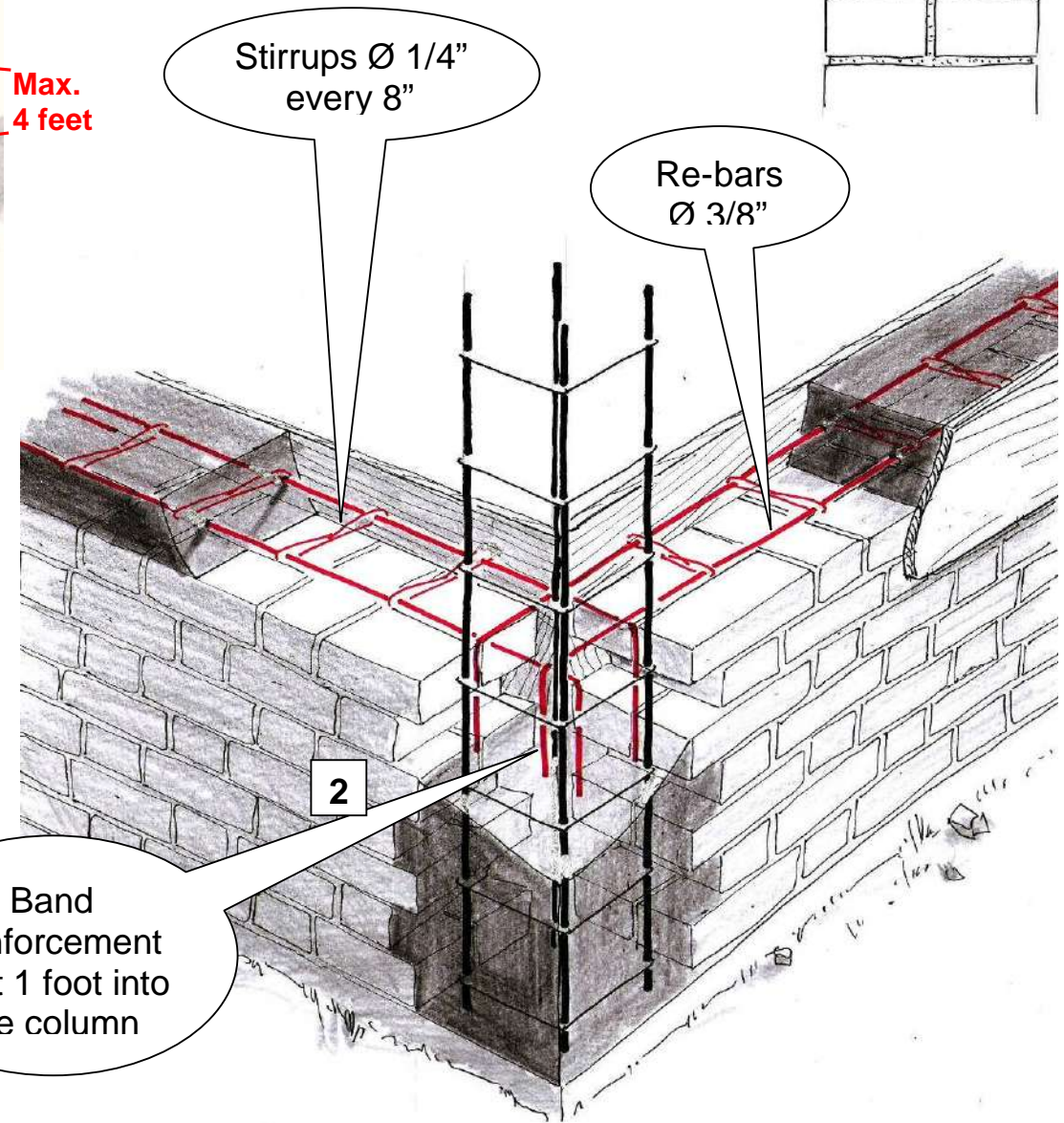
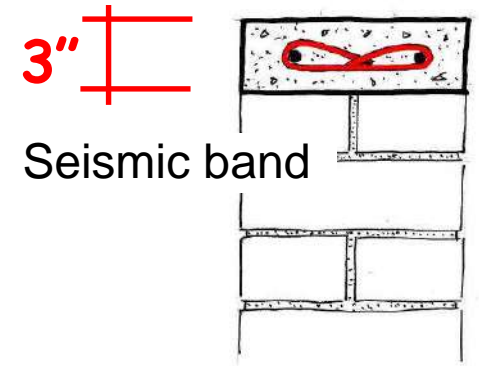
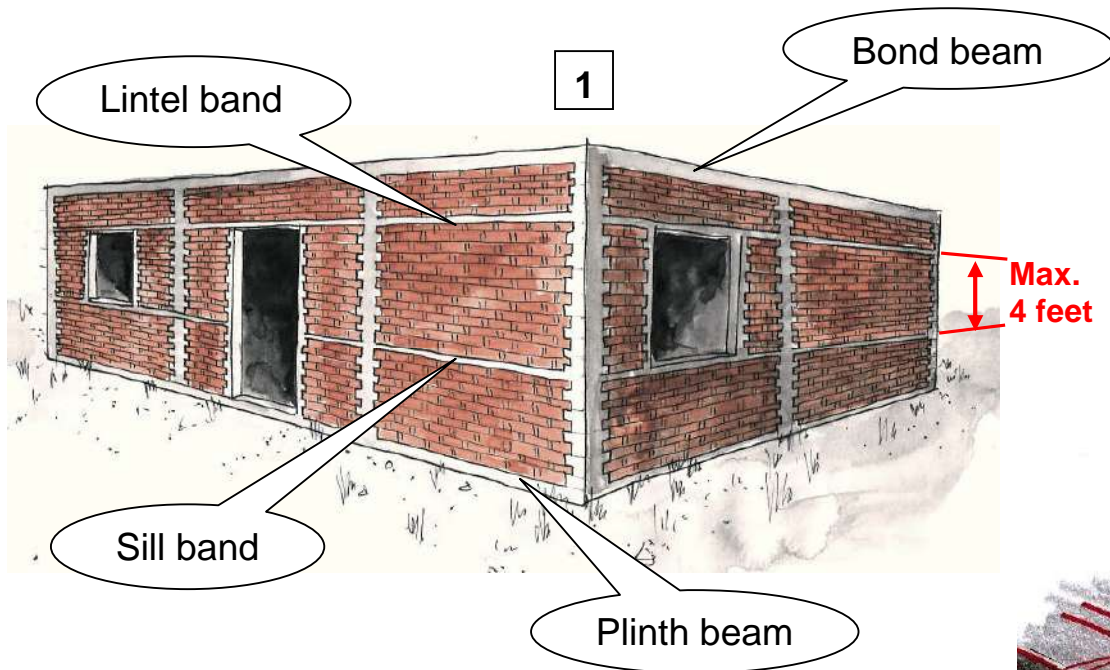

1. Place a seismic band at sill and lintel level, even if there is no window. Maximum distance between bands is 3 feet.
2. Bend the re-bars into the columns (1 foot long).
3. Place the form work for the bands.
4. Pour concrete for the bands and the columns at the same time.

10. Windows and doors

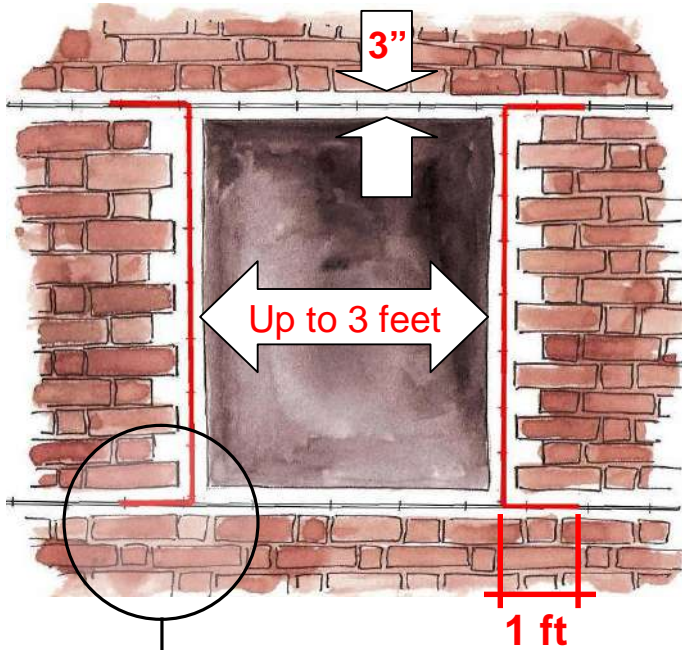

1. Windows and doors must be framed by vertical RC bands.

2. Lintel height:

- For windows up to 3ft, use the normal 3 inch seismic band as lintel.
- For larger windows up to 7 ft, the lintel must be 6 inches high, with additional re-bars.

3. Pour the concrete for the door and window frames together with the lintel bands.

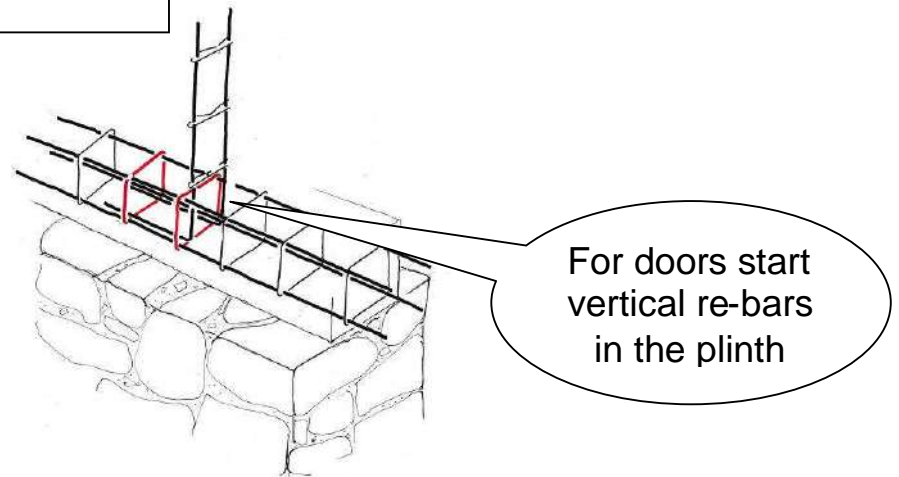
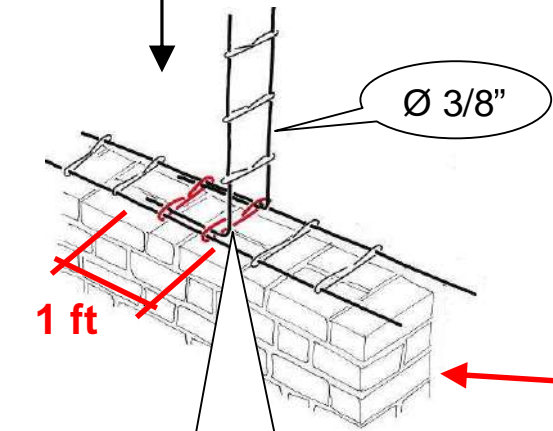
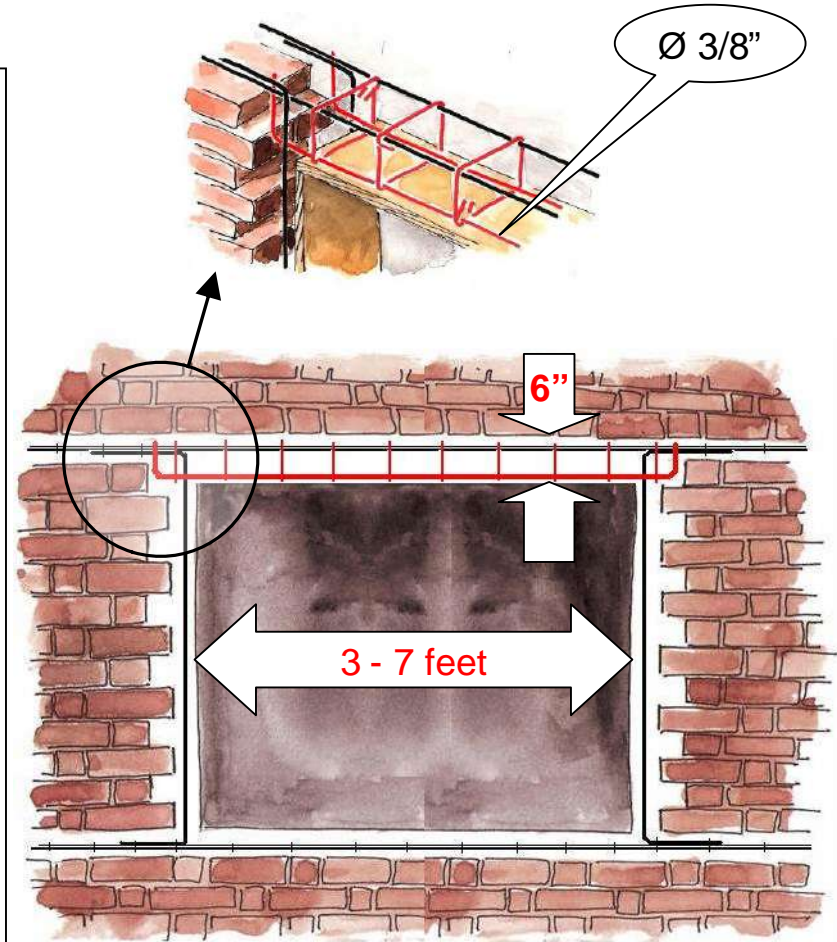

Put footing of vertical re-bars **inside** the stirrups

For doors start vertical re-bars in the plinth

11. Bond beam

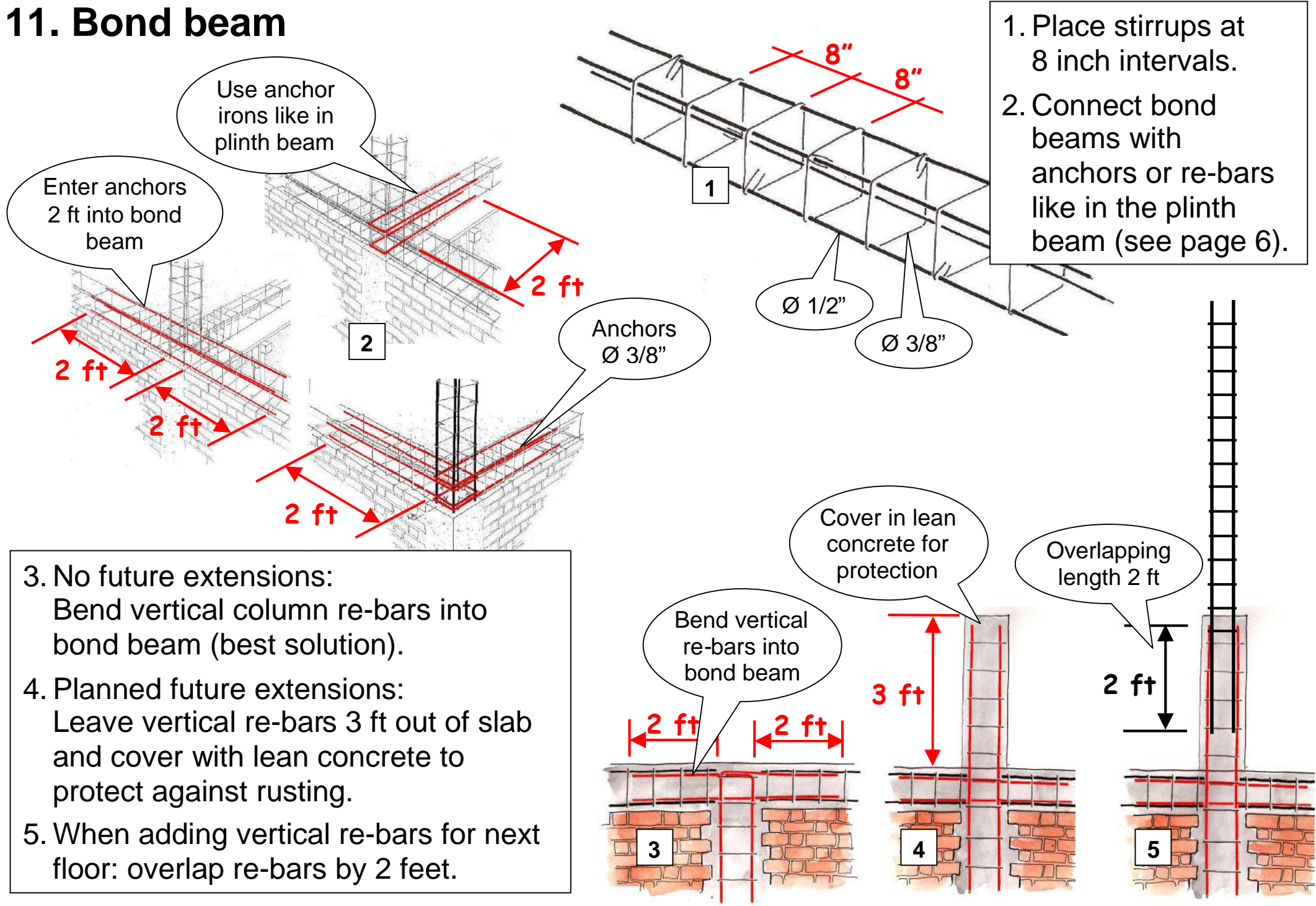

1. Place stirrups at 8 inch intervals.
2. Connect bond beams with anchors or re-bars like in the plinth beam (see page 6).

3. No future extensions: Bend vertical column re-bars into bond beam (best solution).
4. Planned future extensions: Leave vertical re-bars 3 ft out of slab and cover with lean concrete to protect against rusting.
5. When adding vertical re-bars for next floor: overlap re-bars by 2 feet.

12. Concrete roof slab: dimensioning

Span L:

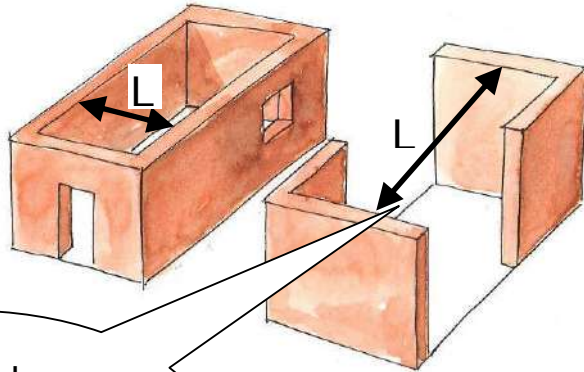

Span L is always the shortest distance between two opposing walls.

Thickness h of slab:

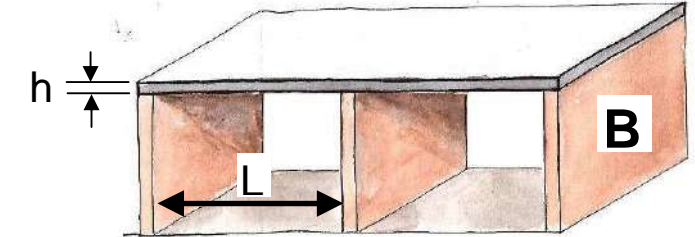
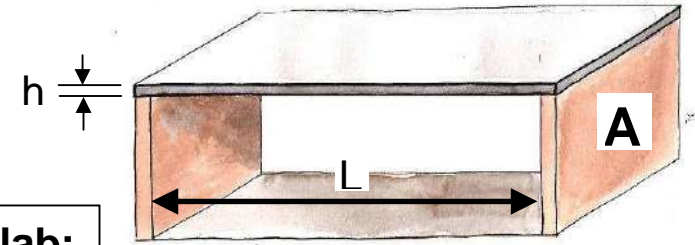

Thickness h of slab:

A: single span $L/20$

B: continuous slab $L/24$

Example:

Single span $L=10ft : h=6''$

Steel reinforcements (re-bars):

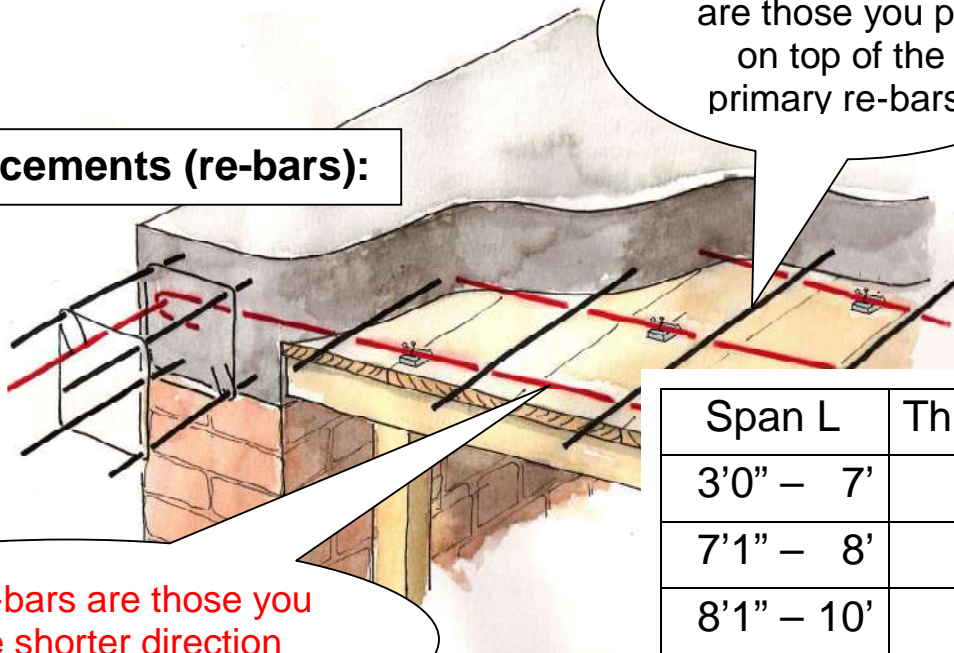

Secondary re-bars are those you put on top of the primary re-bars.

Primary re-bars are those you put in the shorter direction (span). They are placed first.

Span L	Thickness h	Primary	Secondary
3'0" – 7'	4"	Ø1/2" every 12"	Ø1/4" every 8"
7'1" – 8'	4"	Ø1/2" every 12"	Ø1/4" every 6"
8'1" – 10'	5"	Ø1/2" every 10"	Ø3/8" every 10"
10'1" – 12'	6"	Ø1/2" every 10"	Ø3/8" every 8"

13. Concrete roof slab: detailing

1. Place primary re-bars on spacers.
2. Hook primary re-bars onto additional re-bar in the bond beam.

Placing the re-bars:

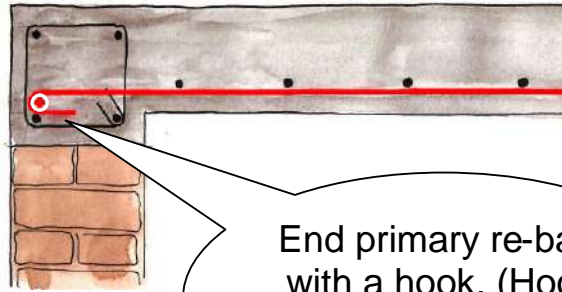

End primary re-bars with a hook. (Hook can look upwards or downwards)

Additional re-bar

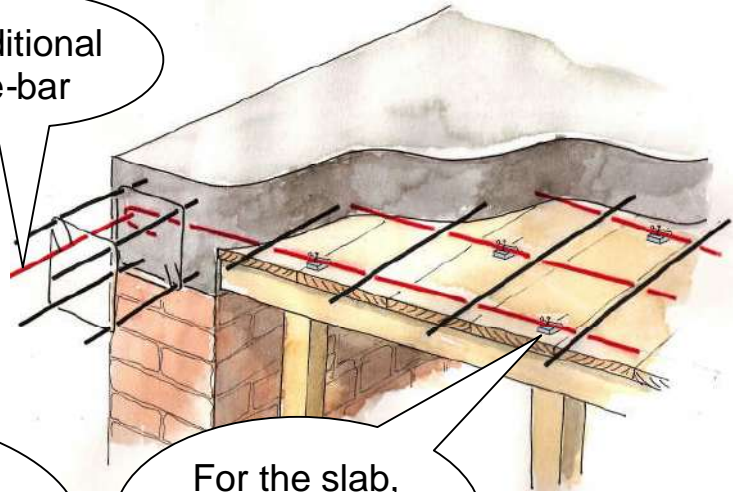

For the slab, use only 3/4" high spacers!

Upper reinforcement:

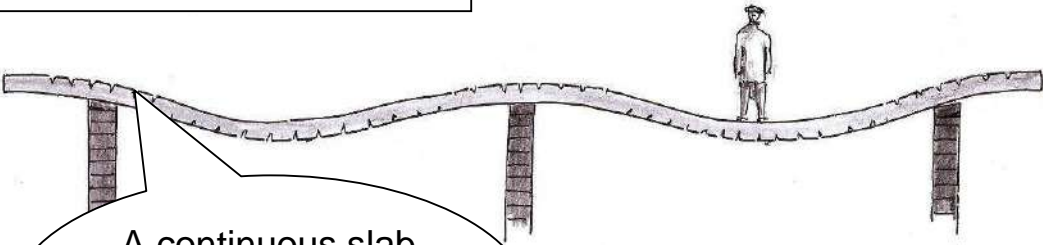

A continuous slab without upper reinforcement would deform and break.

Place chairs to hold top re-bars

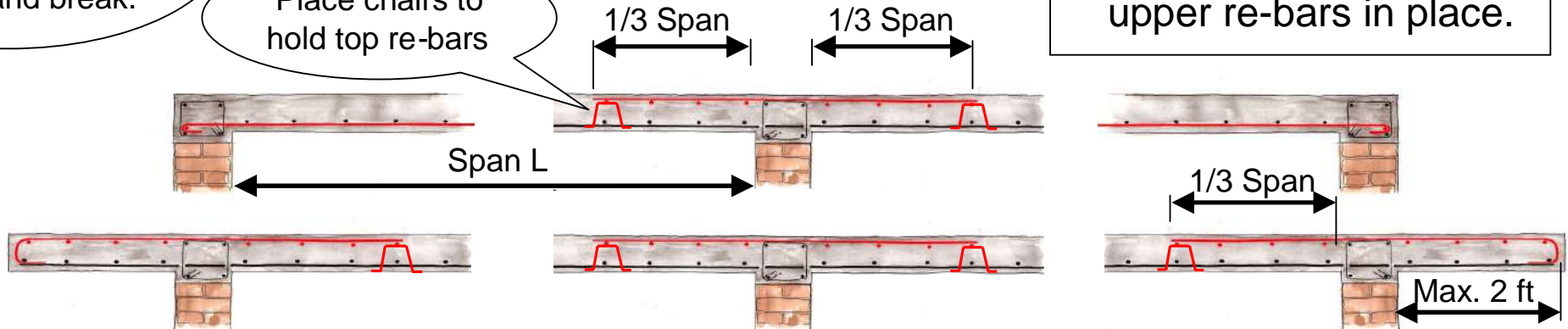

3. Upper re-bars must go beyond the walls for 1/3 of the span.
4. Upper re-bars must be 1 1/2" below surface.
5. Use chairs to hold upper re-bars in place.

14. Extensions of the house

The Crush Zone Concept

- A crush zone will be demolished by an earthquake, but the main houses will be safe.
- Use the crush zone for rooms where people stay only a short time, like a toilet or a storage room.

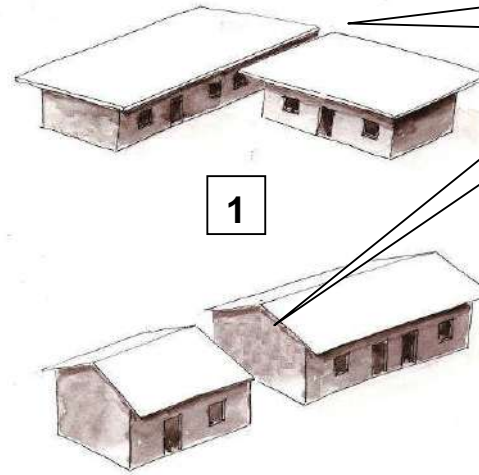

1. Earthquake will rock your house against the next one. To avoid damage, keep a good distance.
2. If you want to stick the buildings together, create a **crush zone** between them.
3. Add a light roof over the crush zone.
4. Put the walls and roofs **against** the existing ones, **not between**, so they can move independently. Don't connect the walls to the house, fill the joints only with plaster.

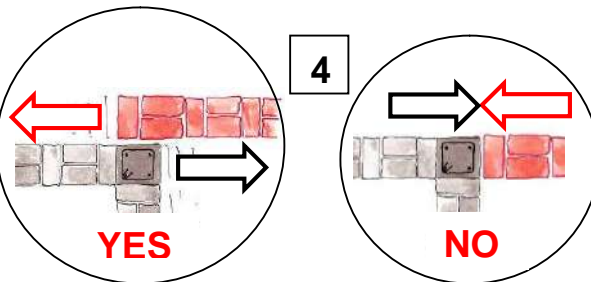
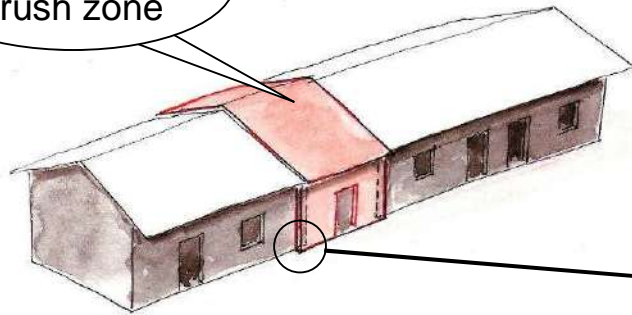
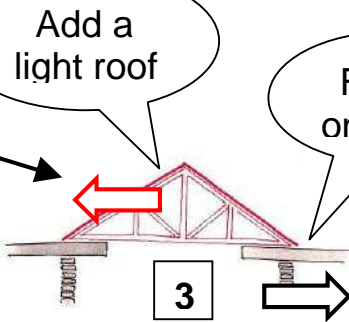
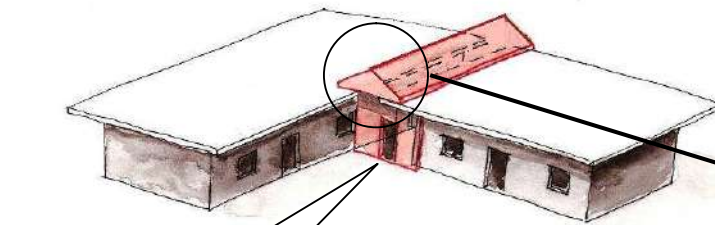

15. The shop window problem

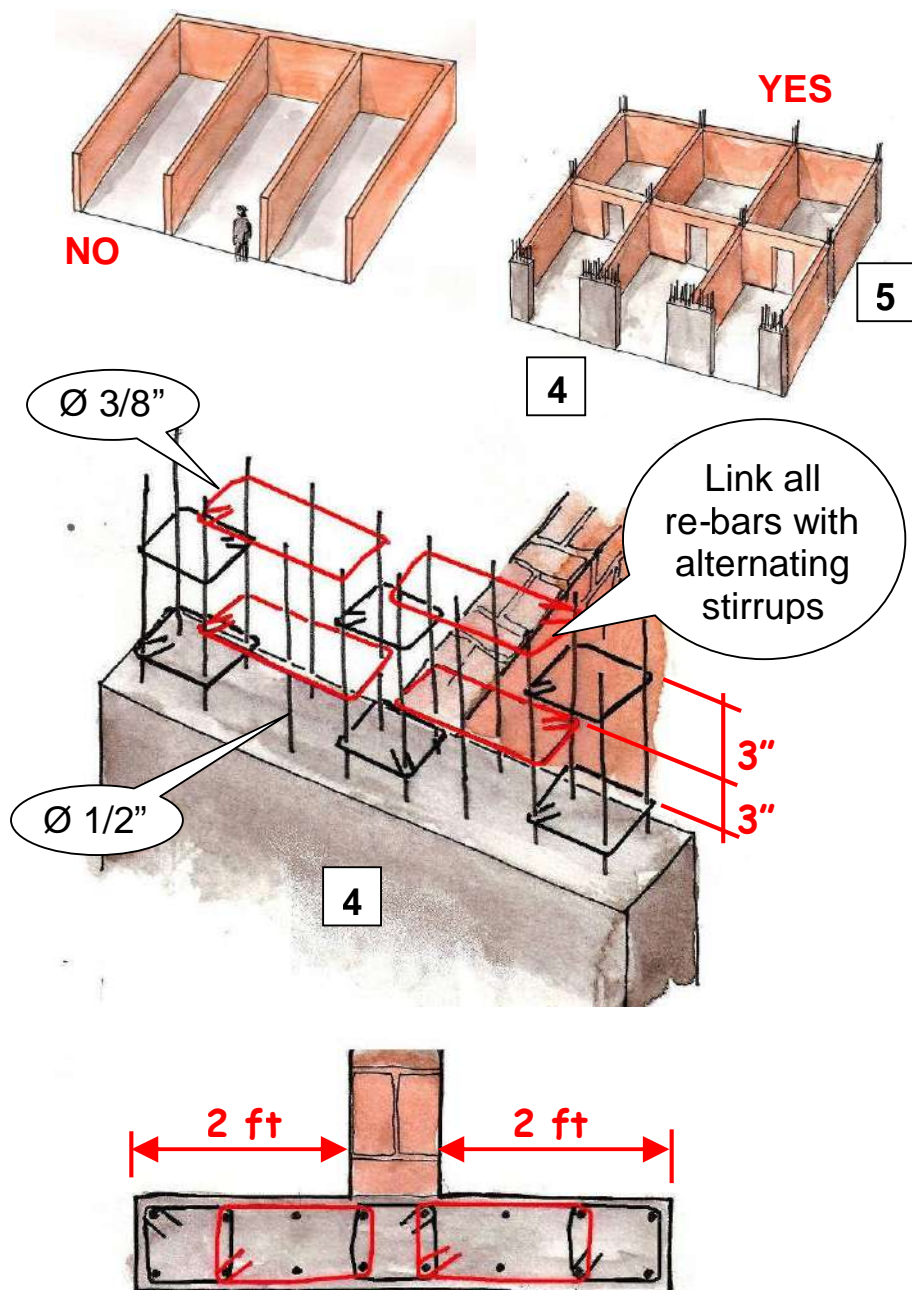

1. Shops are very dangerous structures when it comes to earthquakes.
2. Their big windows make that the building has no resistance to lateral shocks.
3. Walls are often too long and cannot withstand an earthquake.
4. Reinforce the sides of the shop windows with concrete columns 2 feet large.
5. Subdivide long walls by introducing perpendicular walls.

Guidebook prepared by the
Swiss Agency for Development
and Cooperation SDC
(Tom Schacher, technical advisor)



In collaboration with:

ICRC, SwissRe, Swiss Solidarity,
UNESCO, Tom Schacher (Financing of
pre-disaster R&D)

UN Habitat, NSET and NESPAK
(technical inputs)

French Red Cross (Translation into Urdu)

Mansehra, 6 March 2007